

# GRUNDFOS POMONA SELF-PRIMING CENTRIFUGAL PUMP



# Pomona

Multifunctional applicable and robust!



dewatering



cooling lubrication liquids

## Field of application Grey water:

### Construction dewatering, agriculture and flooded areas

- dewatering of excavations, pipelines or pits
- lowering subsoil water levels
- irrigation of fields, sport grounds or parks
- draining of pipelines or pits

### Product advantages:

- robust compact design
- self-priming
- semi-open impeller
- insensitive to impurities
- handling of liquids containing solids or grain sizes up to  $\varnothing 30\text{mm}$
- variable application via multifunctional variants
  - with bearing block and bare shaft end
  - with electric motor
  - with diesel or petrol engine
  - mobile application with carrying frame or trolley

## Further application fields:

### Industry and inland navigation

- pumping slightly impurities in chemical fluids
- pumping cooling lubrication liquids for machine tools
- scavenge pump in filter systems
- fire or bilge pump for the inland navigation market

## Product range:



For stationary or mobile applications with carrying frame or trolley.

## Performance range:

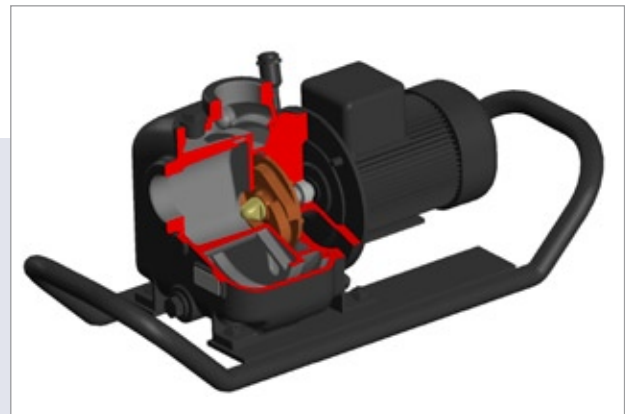
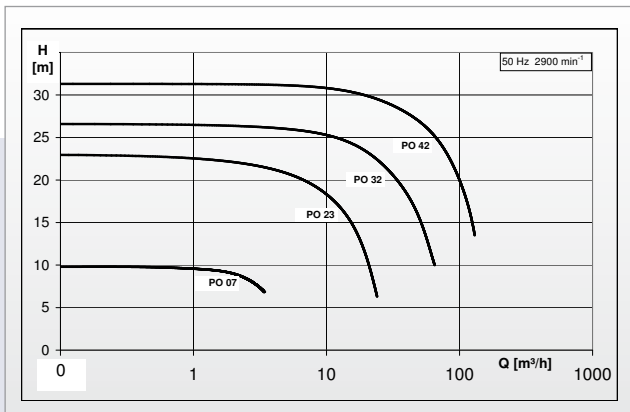

Info: 60 Hz variants with 3600 min<sup>-1</sup> on requests

## Technical Data:

Maximum flow:	130 m <sup>3</sup> /h
Maximum head:	31 m
Maximum suction height:	up to 8 m (5 m with PO 07) at water of 20°C
<b>Equipments:</b>	
Wear plate:	replaceable
Pump mounted on carrying frame:	optional
Pump mounted on trolley:	optional
<b>Accessories:</b>	
Pressure connection set	discharge connection with hose coupling
Suction set	spiral suction hose assembled with discharge connection, foot valve and strainer

**Individual  
customised versions**

Gladly we offer individual customised solutions to you.  
Please contact us: [www.grundfos.com](http://www.grundfos.com)

#### **BE responsible**

Being responsible is our foundation. We know that we have a responsibility towards the people who are Grundfos, towards the innovative soul of Grundfos as well as towards the surrounding world. Whatever we do, we make sure that we have a firm and sustainable basis for doing it.

#### **THINK ahead**

Thinking ahead makes the innovations possible. We encourage a certain Grundfos way of thinking which is founded upon the belief that everyone must contribute by using his or her judgement and foresight. We are looking for commitment and ideas in everything we do in order to make the best solutions. We think – and then we act.

#### **INNOVATE**

Innovation is the essence. It is the innovations that make Grundfos unique. We stand out because of our ability to constantly create new solutions to the ever-changing demands of the pump business. We meet every challenge and we are never afraid of taking the initiative – remaining true to our ideals calls for renewal. Innovation is the soul of Grundfos.